

FLOYD

How to Assemble:

The Bedside Table (Non-Powered)

FLOYD

Components

1x Bedside Table

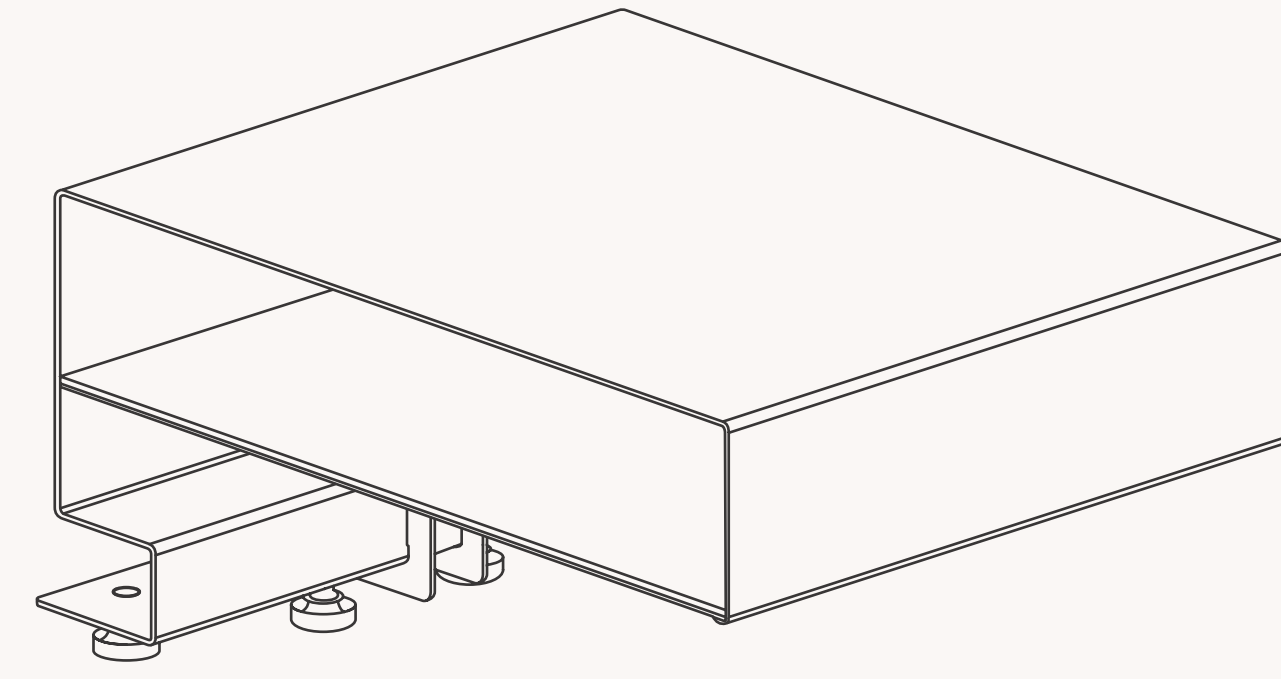

Pro Tip: If you're considering a return, save your packaging!

FLOYD

Step: 1

Start by loosening all 4 pre-attached thumbscrews. Note: You do not need to completely remove the screws.

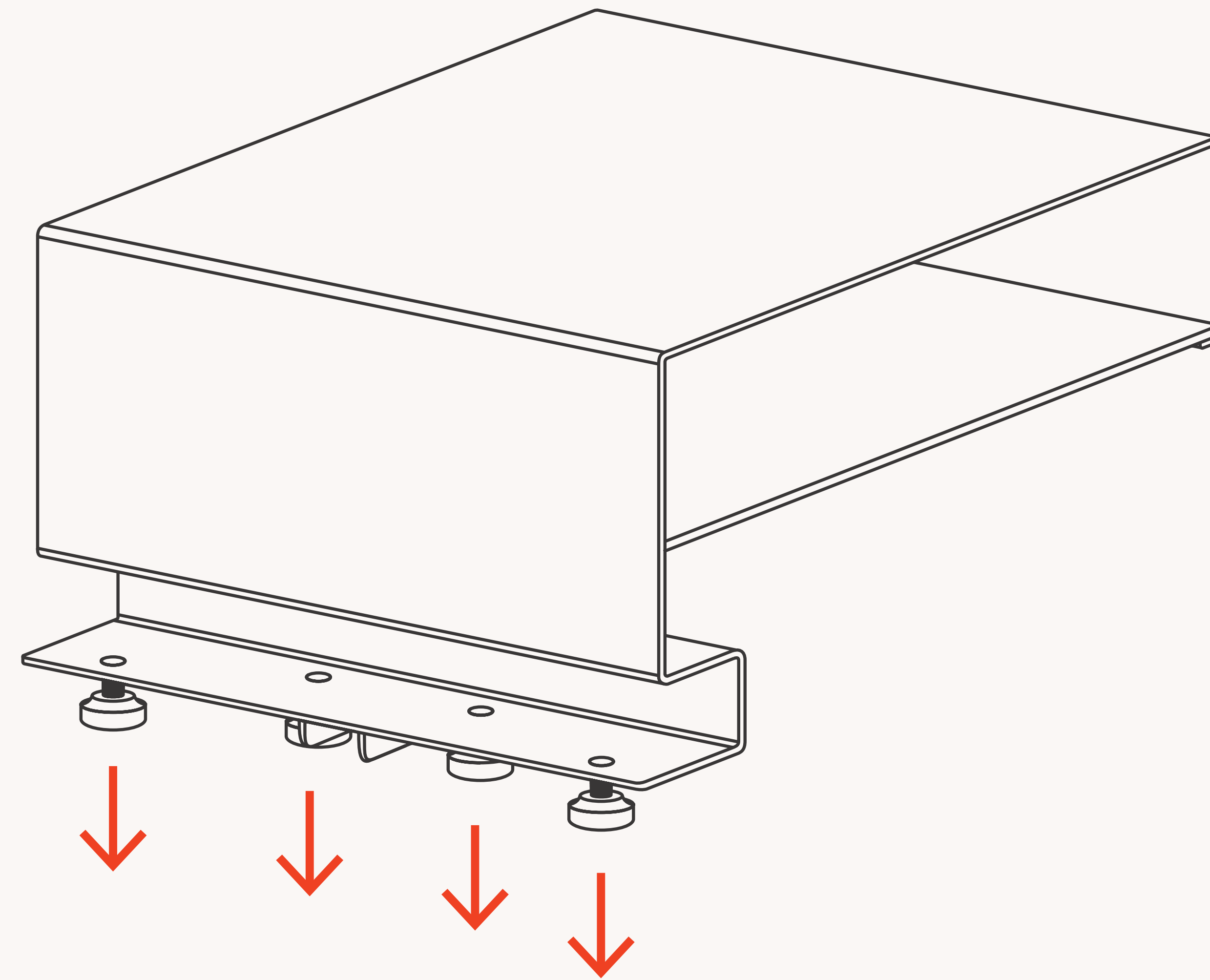

FLOYD

Step: 2

Choose a side of the bed and align the Bedside Table toward the head of your bed, next to the first support.

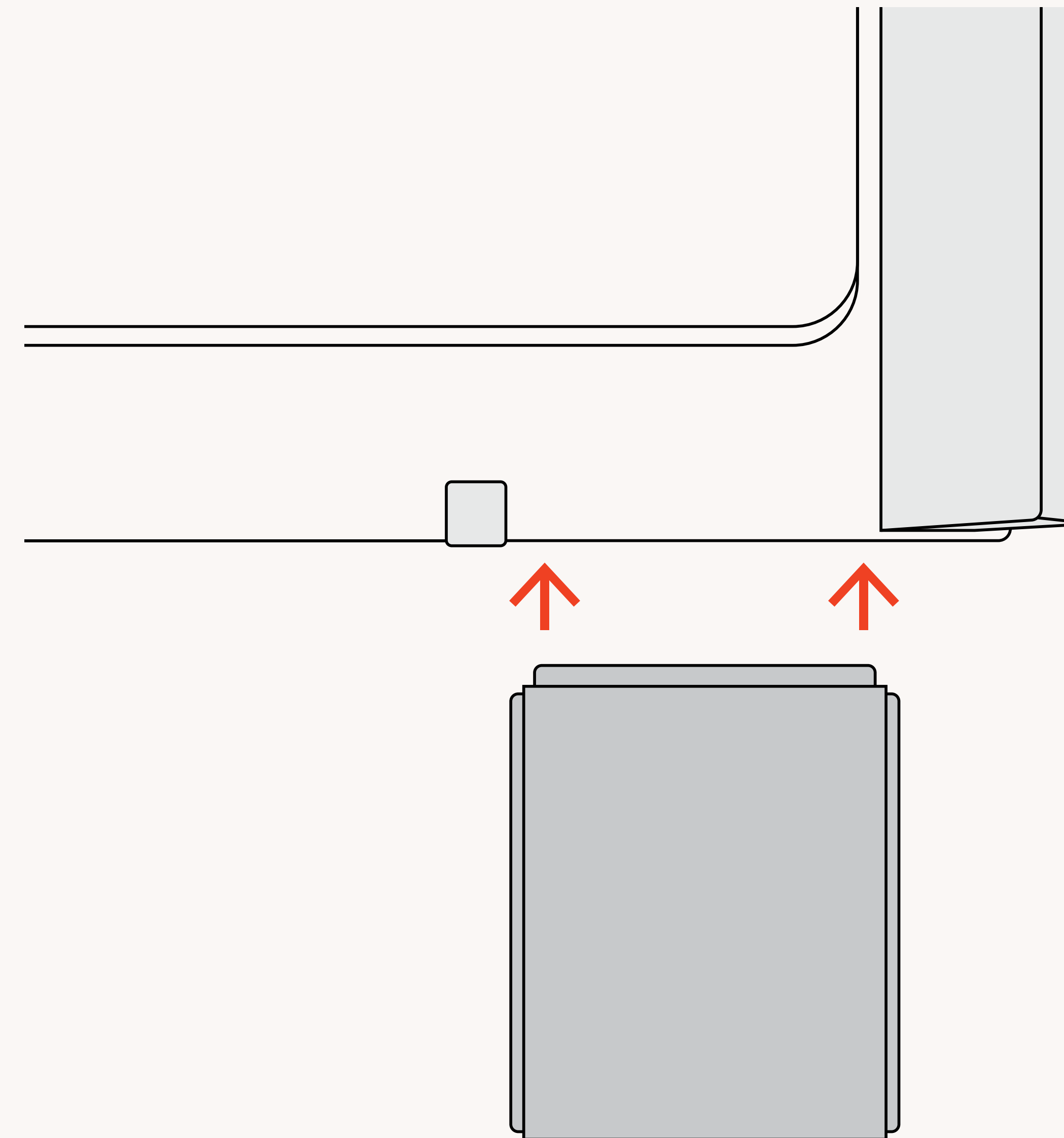

FLOYD

Step: 3

Making sure there is no gap between the table and first support, tighten each of the 4 thumbscrews to attach the Bedside Table to the bed panel.

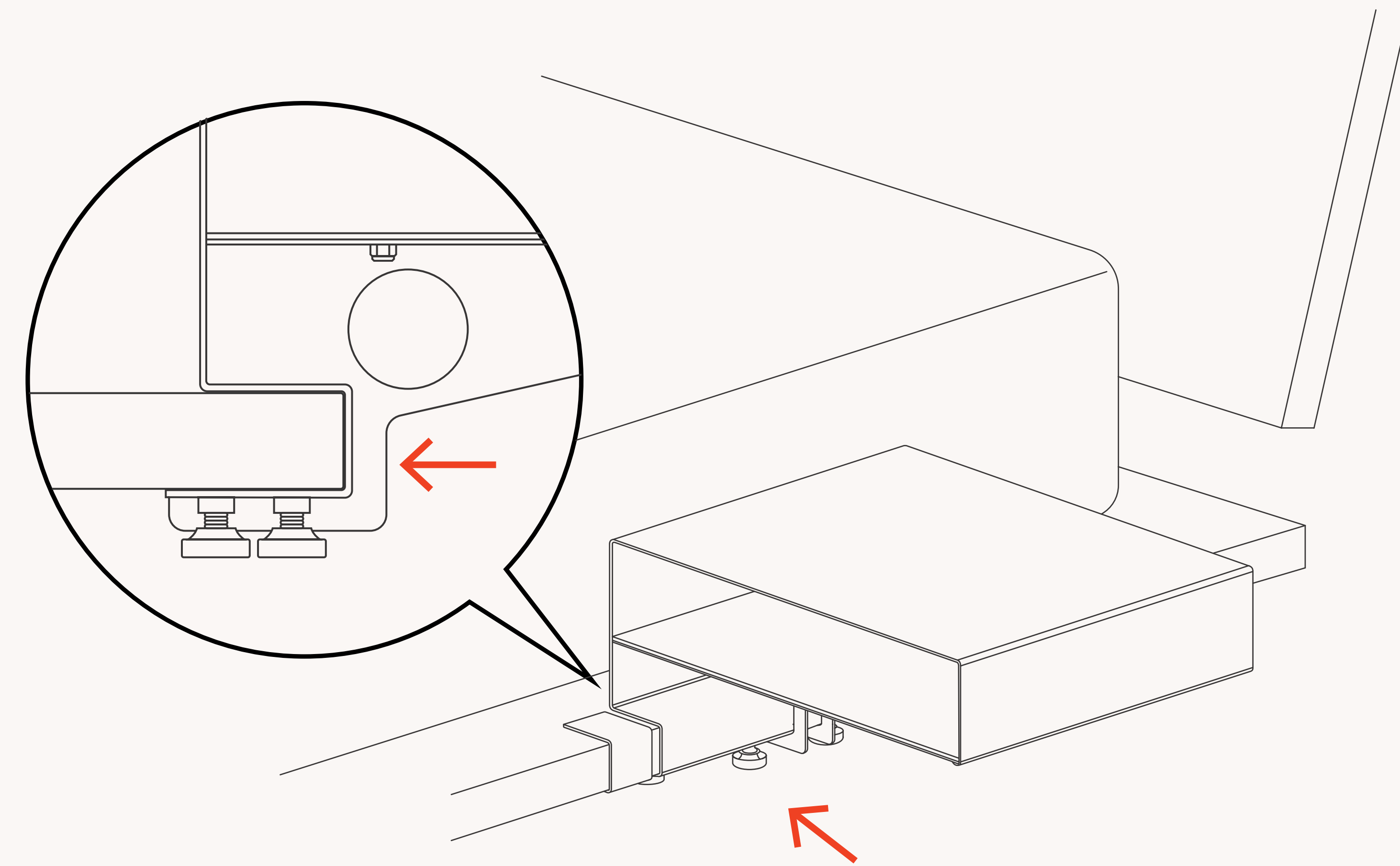

FLOYD

Step: 4

While holding the Table in place, tighten each thumb-screw to securely fasten the table to the bed panel.

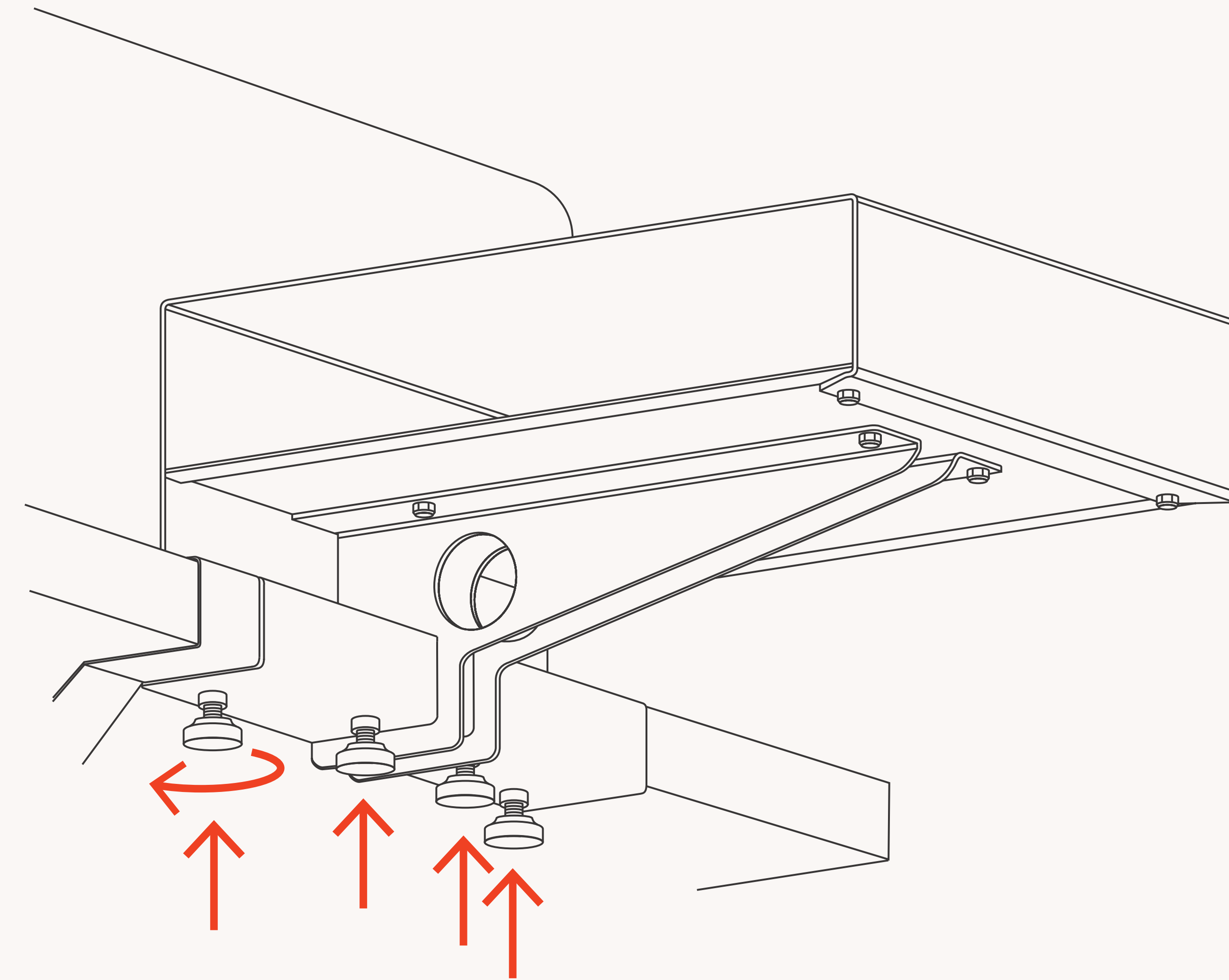

FLOYD

Step: 5

Before use ensure that the Bedside Table is stable.

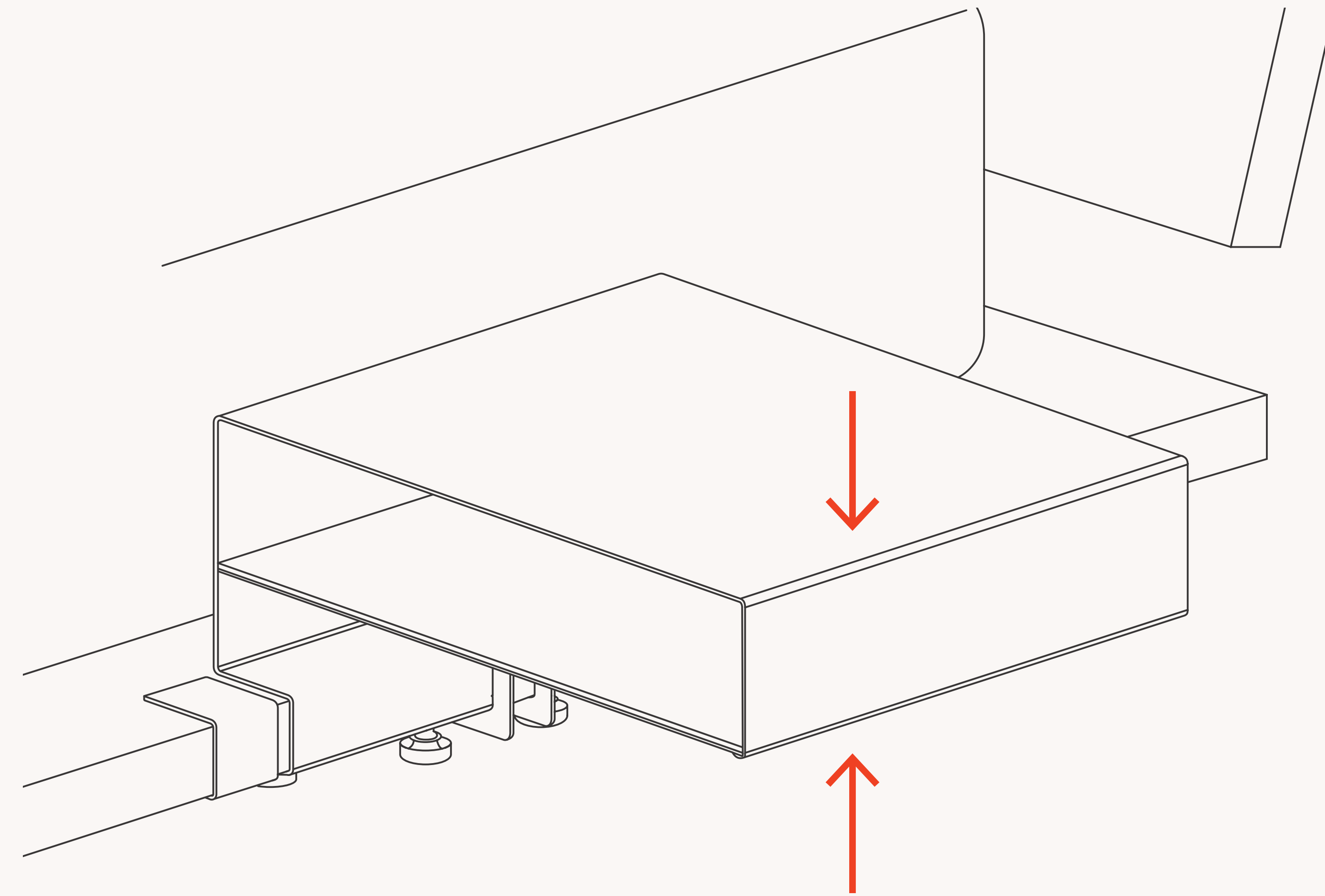

Step: 6

Your Bedside Table is now ready to use!

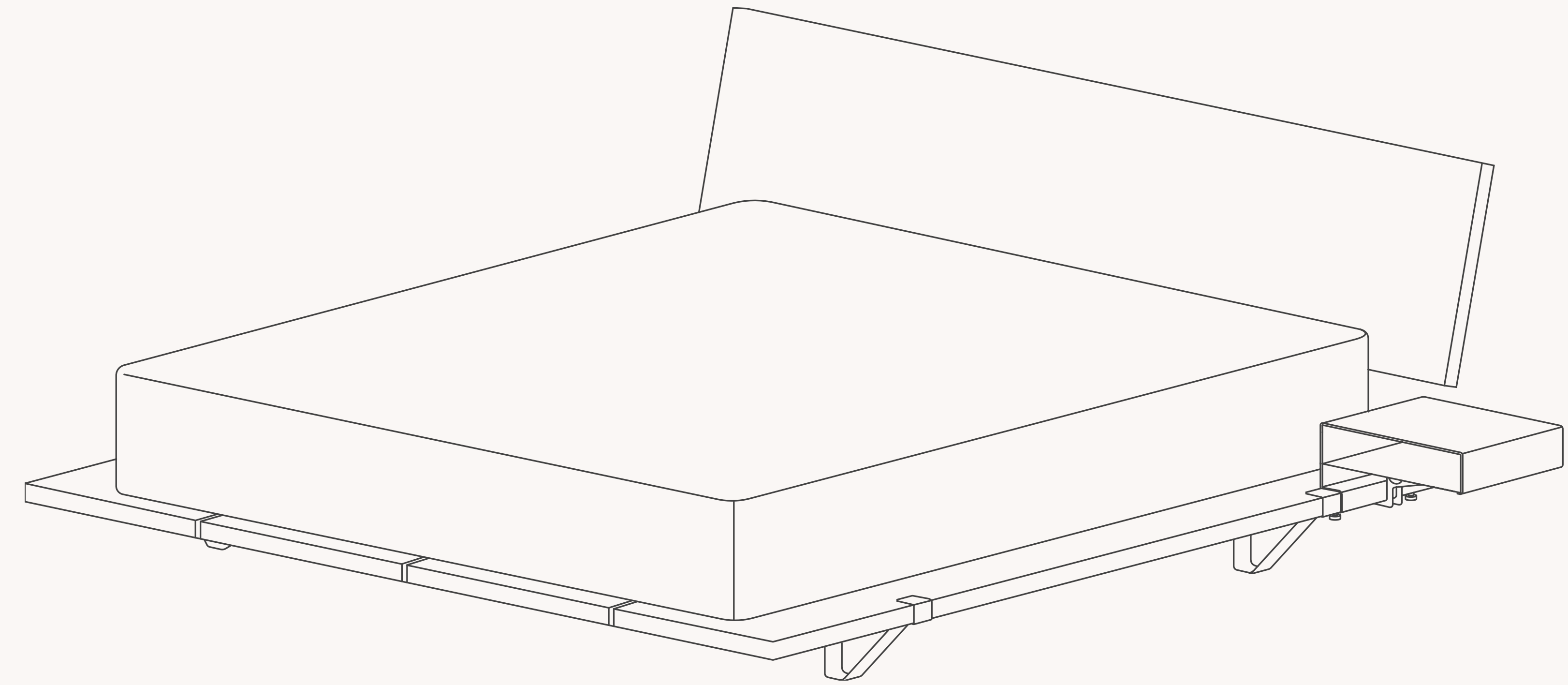

FLOYD

WARNING ▲

READ ALL INSTRUCTIONS **BEFORE** ASSEMBLY & USE. ADULT ASSEMBLY REQUIRED. KEEP SMALL PARTS AND PACKAGING AWAY FROM CHILDREN

NOTES ON USE:

Keep children and others safe by following these simple rules:

Do not allow any child to play on furniture

Do not allow climbing on any piece of furniture

Do not allow hanging from any piece of furniture

Assembly:

Use caution when assembling. Do not change the specifications or modify this product. Incorrect assembly can cause product to fail and cause damage or personal injury. Double check that product is assembled correctly and all components are properly tightened before use.

Usage:

Remove all packaging before first use.

Only meant for indoor use.

Cleaning/Care:

Clean bedside table add-on with a dry or damp lint free cloth.

FLOYD